

# Information modeling approach for integrated logistic services in supply chains ecosystems

## Modellierungsansatz für Informationsmodelle von logistischen Dienstleistungen in Supply-Chain-Ökosystemen

Emanuel Skubowius<sup>1</sup>, Christian Prasse<sup>1</sup>, Benjamin Korth<sup>1</sup>, Jens Leveling<sup>1</sup>, Timo Erler<sup>1</sup>, Michael Schmidt<sup>1</sup>, Johannes Pieperbeck<sup>2</sup>, Gong Wang<sup>3</sup>, Filip-Martin Brinkmann<sup>3</sup>, Vincent Zupancic<sup>4</sup>,

<sup>1</sup> Fraunhofer-Institut für Materialfluss und Logistik IML, Dortmund

<sup>2</sup> Fraunhofer-Institut für Software und Systemtechnik ISST, Dortmund

<sup>3</sup> SICK AG

<sup>4</sup> Schenker AG

**T**his paper describes a procedure for generating information models for (hybrid) logistic services in horizontal value networks. The goal is to enable a fast integration of platform services via open-source information models and to significantly reduce the coordination effort between individual partners in the supply chain. By publishing and sharing the free information models for the respective standard logistic functions, de-facto standards are to be achieved. Through the joint development and adaptation of information models in a community, the development risk is shared and, depending on the size of the community, the quality, the accuracy of fit, and finally the acceptance are increased. After a basic introduction concerning collaborative logistic systems, the state of the art in science and technology for the addressed subsectors is described. Chapter 4 motivates the need for unified information models in the context of platform economy. The general solution approach is presented in Chapter 5, and the approach is exemplified in a use case in Chapter 6. A summary, a conclusion, and an outlook are presented in Chapter 7.

[Keywords: Information model, open source, logistics services, Silicon Economy, data economy, platform economy, International Data Spaces, B2B platforms]

**D**ieser Beitrag beschreibt eine Vorgehensweise zur Generierung von Informationsmodellen für (hybride) logistische Dienstleistungen in horizontalen Wertschöpfungsnetzwerken. Ziel ist es dabei, über Open Source Informationsmodelle eine schnelle Integration von Plattformservices zu ermöglichen und den Abstimmungsaufwand zwischen einzelnen Partnern in der Supply Chain signifikant zu reduzieren. Über die Veröffentlichung und das kostenfreie Teilen der Informationsmodelle, für die jeweiligen logistischen Standardfunktionen, sollen de-facto Standards erreicht werden. Durch

das gemeinsame Entwickeln und Adaptieren der Informationsmodelle in einer Community wird zum einen das Entwicklungsrisiko geteilt und zum anderen, je nach Größe der Community, werden die Qualität, die Passgenauigkeit und schließlich die Akzeptanz erhöht. Nach einer grundsätzlichen Einführung in das Thema Kollaborative Logistiksysteme wird der Stand der Wissenschaft und Technik für die adressierten Teilbereiche beschrieben. In Kapitel 4 wird die Notwendigkeit von einheitlichen Informationsmodellen im Kontext der Plattformökonomie motiviert. Die Vorstellung des generellen Lösungsansatzes erfolgt in Kapitel 5. Der Ansatz wird in Kapitel 6 durch einen Use Case beispielhaft beschrieben. Eine Zusammenfassung, ein Fazit und ein Ausblick erfolgen in Kapitel 7.

[Schlagworte: Informationsmodell, Open Source, logistische Dienstleistung, Silicon Economy, Datenökonomie, B2B-Plattformen, Plattformökonomie, International Data Spaces]

### 1 INTRODUCTION

Supply chains are becoming more and more complex. They require advanced digital solutions that are specifically designed for the logistic industry [Hof17]. Internet of Things (IoT) devices provide the foundation for the next generation of smart, sensor-based, connected logistic solutions. Meanwhile, new data technology such as International Data Spaces (IDS) enables secure and decentralized data-exchange between IoT-enabled participants of the supply chain. However, data exchange between supply chain partners still remains challenging, for instance due to a lack of standards and different data formats, or also due to a lack of trust. Nevertheless, a common language or standards are necessary for every data exchange. For this reason, an approach for generating an information model for logistic applications within the Silicon Economy (SE)

Ecosystems is presented in this paper. The information model gives a holistic overview of necessary information to support data-driven execution of a representative process for real logistics/production as well as to exploit new business relationships.

## 2 COLLABORATIVE LOGISTICS SYSTEMS

Logistics describes the ‘reasonable’ movement of things, in places, through time, and in relations. It is a fundamental principle that permeates everything physically and its movement. At the same time, it is an expression of human beings’ striving to set things in motion. Based on Delfmann et al. [Del18], we will define logistics as an applied science, as an industry as well as an operational function. Logistics analyses and designs economic systems as flows of objects (above all, but not exclusively: goods and people) in networks, supplying recommendations for action on the design, implementation, and operation of these networks [Hom21].

The new generation of supply chains will be characterized by a further increase of cross-company collaboration not only for the flow of material/goods, but also for data [Gei20]. Therefore, supply chain partners are striving to implement easy data exchange, maximum real time transparency, and seamless interoperability of their individual digital ecosystems.

Every movement of goods generates various data. To execute any task, be it in the field of planning or execution, this data must be exchanged (e.g., from a producer or wholesaler to the end customer). At present, data is often still exchanged manually. Normally, the process digitalization stops at the company boundary in the local ecosystem. The key barriers for building up the consistent digital collaboration along the supply chain are obvious and proved: Firstly, IT interfaces between companies, even in one company, vary because there is no uniform, convincing and intuitive technical solution for all partners. Secondly, companies have a lack of trust to share their own sensible data using public network.

Modern collaborative logistic systems attempt to overcome these challenges and strive for the transparent, reliable, and secure transfer of data between supply chain participants [Cam04]. This requires an information model that is widely accepted by supply chain partners, which then enables sustainability and expandability of collaborative logistic systems alongside horizontal supply chains.

## 3 STATE OF THE ART

This chapter provides an overview of the state of the art in the relevant subject areas.

### 3.1 DIGITAL AND HYBRID LOGISTICS SERVICES

The approach, presented in this paper, of defining an information model is based on two interlinked ideas – the concepts of smart services and servitization. Smart services and servitization shall be understood as follows:

*Smart services* are defined as data-based digital service offers. They are built on smart products or cyber-physical systems, i.e., a network of IT and software components with mechanical and electronic parts that communicate via a data infrastructure such as the Internet [PSE20]. Put simply, *servitization* means that the classic process of selling a product (once) is replaced by selling products as a service [KGK17, KP17]. Streaming service providers such as Netflix or Spotify are perhaps the most prominent representatives of such “as a service” offers (delivering media as a service instead of CDs, BlueRay-Disks, etc.).

Logistical service provision has always been a service per se. At the same time, the classic logistic service (in the sense of transport, handling, storage) is always tied to the physical flow of materials. If now (i) the logistical service provision is digitally recorded (e.g., supported by IoT devices and other (mobile) data collection devices) and (ii) accompanied and supplemented by digital services (e.g., web services/apps), it is possible to develop smart logistic services. The scope and value creation potential of smart logistic services are significantly higher than the level of non-digitized services. This is for example the service provision or utilization can be made more flexible (e.g., in the sense of service scaling) and the service offering can be expanded and deepened (e.g., offering transport plus tracking and tracing, offering goods availability and inventory transparency instead of simple provision of goods). The provision of logistic services in this sense requires certain technical and professional prerequisites. These will be briefly addressed in the following two sections.

### 3.2 PLATFORMS AND SERVICES

A digital platform is an open IT infrastructure operated by companies to offer services to platform users, whereby companies can operate several (independent) platforms. A platform can be located in a cloud environment, a company's own IT infrastructure (also referred to as on-premises), or both (hybrid).

Microservices have received a wide adoption in the industry among companies building large-scale applications like Amazon and Netflix, as well as Platform-as-a-Service (PaaS) providers like Pivotal [Mel14]. The target software is composed of a set of fine-granular services which enable simple, independent distribution, as well as independent changes and extensions. Smaller software solutions are created, which ideally have experienced a specialization in a subject area. This logical encapsulation has many advantages: Stakeholders can, for example, write their services in their preferred programming language. Thus, there

is no need to learn a cross-system programming language to extend the system or platform. Furthermore, this architectural style simplifies the (horizontal) scaling of a platform. If more computing capacity is needed, more instances of existing microservices can be created with less effort. A load balancer is then used to distribute the load in the system among the existing microservices. Each microservice can be located in a different place and implemented using a different technology. They communicate with each other using lightweight protocols such as HTTP(S).

Self-contained systems (SCS) [INN21a] divide a system into independent web applications built with microservices, which should preferably have asynchronous application programming interfaces (API). The currently preferred architecture follows the Independent Systems Architecture (ISA) best practice guidelines [INN21b].

Another challenge in platform development is solved by so-called containerization. Usually, there are problems running a software on different hardware. Even with identical hardware, the software may not be executed due to a different configuration of the operating system. First solutions have outsourced the execution of the software in virtual machines (VM). These bring along their own operating system and virtualize the complete hardware, so a certain execution of software could be guaranteed. However, virtual machines have the disadvantage that they place high demands on performance, since a complete operating system must be run. This problem has been alleviated in the context of so-called containerization. A microservice is always delivered and executed in exactly one application container. Containers include not only the application or microservice itself, but also all the required dependencies. These contain runtime environments and system libraries. In contrast to virtual environments or virtual machines, containers use core functionalities of the underlying operating system and are therefore more lightweight in comparison. Via the so-called container engine, the individual applications in the containers share the functionalities of the operating system of an underlying computer. The execution of the containers is also managed by the container engine. Individual containers can be configured, started and stopped through the engine. In industry, currently Docker [Doc21] represents the de-facto standard. In combination with the microservice approach, this provides a flexible, powerful solution for the design of digital platforms, enriched with logic in a stakeholder-agnostic manner.

Despite the strong encapsulation of the microservices in functional blocks and in containers, the question of how to orchestrate these services still arises. Here, higher-level execution layers such as Kubernetes [Kub20] have proven to be a useful solution. Kubernetes was created in conjunction with Docker and offers a number of automated features. For example, Kubernetes searches for computers with free resources and autonomously launches corre-

sponding containers there. Even if systems fail due to intermittent network communication or hardware defects, Kubernetes autonomously creates new instances of the missing containers. Hence, Kubernetes clusters manage individual microservices, provide the required IT resources and control their execution. Today, it is common for individual services to be connected to each other via message brokers and to combine the individual functions into a process. For more complex processes, consisting of several services whose interconnections are rule-based, it is recommended to orchestrate the individual services into an overall process. Rule-based routing engines such as Apache Camel or workflow engines such as Camunda Platform are particularly suitable for this. Routing Engines focus on the technical aspects, i.e., the transformation of message formats and communication protocols between different formats and standards for a simplified interconnection of different services. Workflow engines manage the execution of individual process activities (in the Silicon Economy, a business activity is implemented by a service) and the control of when which activity is required. Workflow engines support a visual modeling of processes. Workflow engines cannot be clearly distinguished from rule-based routing engines, as products provide functions from both. As an alternative to the mentioned open-source solutions (both are available under Apache License 2.0), commercial products such as ARIS from Software AG can also be used. Cloud providers also offer their own solutions. At AWS, the AWS Step Functions [AWS21] orchestrates microservices (called Serverless Application at AWS) into complex workflows (and thus processes).

The interfaces of microservices, especially concerning data flow, must be precisely specified in all cases (e.g., OpenAPI-compliant for REST). To reduce overhead, interfaces for configuration, logging, etc. should be standardized. This embeds them in a minimal stable macro-architecture that defines specifications for all microservices.

### 3.3 DATA MODELING

Data modeling is one of the most important factors when it comes to data exchange between many stakeholders. The objective of data modeling is to design a data structure (e.g., for a database) that fits as well as possible to a relevant (business) world. Just like the visualization of the (business) process through modeling, the classification, aggregation, and generalization of the information are highly relevant. The essential background is the understanding between all participants about the process and information which is crucial for the development of interoperable software components and the operation of software services. Standardization of data models (data definitions, formats, names, etc.) is an important element in making integration efficiently. Various professional and technical (data) standards exist in and for logistics and supply chain management (see e.g., Table 1).

Table 1. Commonly used data standards and information models in logistics

Data standard	Description
EDIFACT + Subsets	Cross-industry international standard for the format of electronic data in business transactions (> 30 messages), e.g., shipping notification, bordero, invoice, inventory report <sup>1</sup>
VDA (Verband Der deutschen Automobilindustrie) and Odette File Transfer Protocols	Network protocols for direct electronic data transmission between two communication partners, primarily in the automotive industry <sup>2</sup>
BO4L	Business and technical specification of business objects for logistics (BO4L). Starting point: OAGIS (see below); master and transaction data, e.g., handling unit, shipment, delivery bill, purchase order [Böh15]
OAGIS XML Scheme	Canonical, XML-based business language for information integration, defining business messages (e.g., order, invoice) in specific business processes/ integration scenarios (e.g., purchase order process, supply chain execution, vendor managed inventory) <sup>3</sup>
EPCIS	Electronic Product Code-based standard for communicating business events (what, where, when, why?), incl. core business vocabulary e.g., business steps / processes, dispositions / states and transactions / messages <sup>4</sup>

In this approach, the data model of the EPCIS framework was used as the basis for the service-based Silicon Economy information models. On the one hand, this is justified by the event orientation. On the other hand, the structure is suitable for the way of modeling the information and the application proximity to logistics is particularly high. An essential success factor for collaborative supply chains is based on the transparency of events and their execution. Other data models can also provide the basis for this, but it may be necessary to evaluate in each individual case

<sup>1</sup> <https://unece.org/trade/unecefact/introducing-unedifact>

<sup>2</sup> <https://www.odette.org/oftp2>

<sup>3</sup> <https://oagi.org/DesignGuidesandBestPracticesDocumention/tabid/236/Default.aspx1999>

<sup>4</sup> <https://www.gs1.org/standards/epcis-and-cbv-implementation-guideline/current-standard#Index>

whether other standard data models are better suited to the application.

### 3.4 DATA SOVEREIGNTY

The distinction between ownership and possession of data can become a problem in so far as data can be used and reproduced as often as desired without losing quality [Moo99]. Data sovereignty expresses itself in the balance between the requirement to not lose control over one's own data and to enable its common use in business ecosystems [Ott16]. Such business ecosystems are characterized by the joint development of innovative services, end-to-end view at customers and a dynamic formation and resolution [Moo06]. Therefore, technical and legal precautions are necessary to enable digital self-determination over data. Trustworthiness and transparency play a key role, particularly for technical infrastructures, so that these are usually operated by independent institutions which guarantee adherence to the rules. This problem has been recognized in many places; however, practical solutions have not been in sight for a long time.

One approach can be found in the project "ODiL"<sup>5</sup>, which includes the development, implementation, and demonstration of an open software platform for agricultural enterprises. The focus of attention is here on the representation, processing, and communication of data under system-wide enforcement of property and access rights.

The same applies for the "Vertrauenswürdiger Austausch geistigen Eigentums in der Industrie – VERTRAG"<sup>6</sup> project (trustworthy exchange of intellectual property in industry) which was funded by the Federal Ministry of Education and Research (BMBF) in the context of the Research for Civil Security program. It deals with the comprehensive protection of company documents against industry espionage by means of trustworthy platforms. Because of the increasing digitization within data exchange, the focus is on the consideration of the up-to-date encryption and authorization procedures ("Enterprise Rights Management", ERM) which are directly affecting the data stocks.

In 2014, the "Industrial Data Space" (IDS, now International Data Spaces Association, IDSA<sup>7</sup>) initiative came together to preserve digital sovereignty over data and services for business and society. The initiative is supported

<sup>5</sup> <https://www.odil-projekt.de/de/startseite.html>

<sup>6</sup> <https://www.sifo.de/de/vertrag-vertrauenswuerdiger-austausch-geistigen-eigentums-in-der-industrie-2425.html>

<sup>7</sup> <https://www.internationaldataspaces.org>

by companies and BMBF, the Federal Ministry of Economics and Energy (BMWi) and other institutions. IDS positions itself as alternative and supplementing architectural design that stands out from existing concepts that either manage the data centrally and monopolistically or negotiate every single data exchange individually [Ott19]. For this, datasets are paired with usage policies which other IDS participants are enforced to obey when consuming the data.

In the BMBF-funded InDaSpacePlus<sup>8</sup> project (also based on the IDS), various mobility use cases are currently being investigated and verified with partners from the transport provider side. A great deal of interest from various public transfer providers (throughout Germany) was identified and a willingness was signaled to make data records available. This preliminary work can also be included in this project.

IDS is currently the most promising approach to implement secure data exchange in decentrally organized ecosystems with currently over 110 companies and organizations. The (reference) architecture and many software components of the IDS are open source so that they can be used and adapted free of charge.

In the IDS ecosystem, different actors are present. Base entities are provided by IDS connectors, which serve as IDS gateway components, allowing the provision and the consumption of data via standardized IDS message exchange. Other instances, such as the IDS broker, which allows connector and data discovery, or the IDS clearing house, providing clearing and settlement services, are also part of the proposed ecosystem described in the IDS reference architecture model [Ott19].

Data sovereignty also represents a core focus of the Silicon Economy, which embeds IDS technology in each participant's ecosystem to ensure a safe and standardized data exchange. The architecture of the environment for each Silicon Economy participant envisions IDS as a core component. For this, each participant provides an IDS connector, which is used to exchange data via participants to ensure data sovereignty.

#### 4 FEDERAL LOGISTICS PLATFORM ECOSYSTEM

Within this chapter the general approach of a federal, open platform ecosystem in logistics – Silicon Economy – will be presented, including essential components, services, and information models.

#### 4.1 SILICON ECONOMY

The leitmotif of the change toward a Silicon Economy is a new type of cooperation in global, digital ecosystems. Today's rigid and well-defined value chains are being replaced by flexible, highly dynamic, and globally connected value networks. The availability and transparency of relevant data are a key prerequisite for this [PI19] and a decisive driver of innovation and growth.

Supply chains will be connected at all levels – autonomously and in real time. Logistic services will be traded, scheduled and supervised via platforms. Devices will autonomously negotiate and pay. The control loops of logistic planning and scheduling will be closed. Supply chains will autonomously plan, organize and optimize themselves. Consequently, and finally, an autonomous logistic ecosystem will emerge.

The “big picture” of the Silicon Economy shows the complete data chain: from data generation on the Internet of Things (IoT Broker) and the trading and booking of data (Blockchain Broker) to the organization of (logistical) processes (Logistics Broker) with the all-connecting secure data space (International Data Spaces IDS) and the superordinate platforms for the realization of new digital business models (see Figure 1).

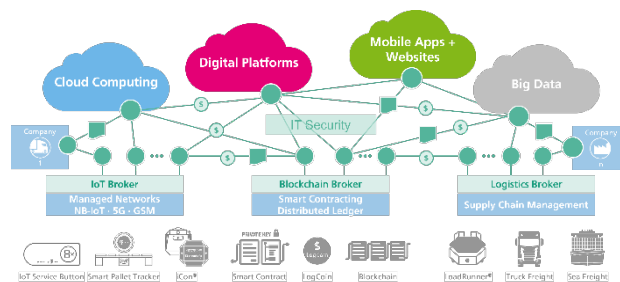

Figure 1.: An open and digital ecosystem as a digital infrastructure for autonomously acting and highly dynamic supply chains

This digital infrastructure enables end-to-end transparency in value networks and creates trust along complete supply chains – from raw material suppliers to end customers – perhaps the most important prerequisite for the participation of all companies. Many of the technologies required for the “big picture” are already available. Starting with logistics, this comprehensive vision could be successively translated into products and business models.

#### 4.2 FROM PROCESS CHAIN TO ORCHESTRATED SERVICES

A key success factor in collaborative logistics, as in horizontal value chains, is the efficient design of supply chains

<sup>8</sup> <https://www.internationaldataspaces.org/wp-content/uploads/2019/09/InDaSpace-plus-Anforderungsdokument-1.pdf>

[Kuh02, Par13]. In terms of the process chain, the transformation towards an open platforms' ecosystem and the associated increasing flexibility mean that the process chain can be easily formed by smaller process steps that are provided by different market players. Hereby, the platforms help to match providers and demanders and accelerate the integration process. Besides the potential to improve the existing business models by making process chains more adaptable to the current market situation, further opportunities for new business models emerge when platforms and service providers allow to share process data and make use of it.

A basic prerequisite to make process steps manageable by platforms is to define them as independent and self-sufficient as possible. Therefore, the process chain has to be decomposed and regrouped in a useful way. That means that sometimes it is not useful to cut processes as far as possible, especially when processes have a strong binding or interfaces are getting too complex.

The result of the decomposition and regrouping are logistic services, that now have to be described in a standardized way. The description should include inputs and outputs in terms of material and information flows and if setup, transformation, or payment information is applicable. Through this, a definition of a logistic service is given, that can be offered on platforms. (see Figure 2).

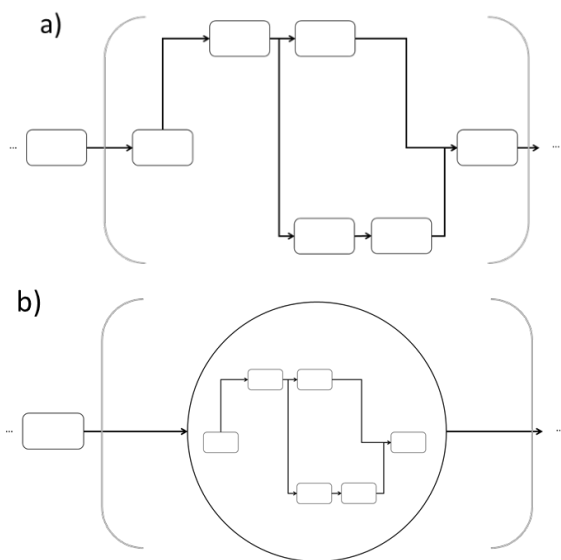

Figure 2.: Consolidation of single process steps (a) to SE services (b)

In the Silicon Economy, a service represents a functional module that participants can provide for other parties to collaborate. These services are standardized in their architecture and integration into Silicon Economy participant environments, thus allowing service discovery via the Logistics Broker, integration of Blockchain technology or the linking of IoT devices via the IoT Broker. Different partic-

ipants of the Silicon Economy can provide different services based on their experience in their respective environments. A Silicon Economy participant can provide any number of services in his environment.

SE services are professional (logistic) services, consisting of IT and/or physical services. They are part of a functional (logistic) process and can be linked and subsequently orchestrated in accordance with the process that is to be supported.

Services are executed and used via platforms. A Silicon Economy Platform consists of one or more services and basic components for integration of physical devices, external interfaces and for service management, its location does not matter (e.g., on-premises, a cloud environment).

SE Services are implemented based on a microservices architecture pattern. This means that the individual components of a service, such as the user interface, database, logic and other components are divided into individual microservices and executed in application containers on a Kubernetes cluster [Lev21].

### 4.3 INFORMATION MODEL

To ensure an efficient execution of the mentioned services (see Section 4.2), it is necessary to define the framework conditions for interfaces, nomenclature, etc. This is done by defining information models. Information models can be found on several levels. For federated logistic platforms, we consider three different levels of data description as relevant: an information model for the data exchange perspective, for the service perspective and for the platform perspective (see Figure 3). For data exchange, the metadata information model of the International Data Space requires consideration. It describes the metadata and all data relevant for data exchange itself around the actual content of a message. The Data Space Connector operates according to this model. For the execution of services, other data models are used to describe the content of the messages. Information models describe the services themselves and what data the services exchange or provide. We first foresee an information model for each service – a so-called service-based information model. Information that is common to different services can then be described in higher-level conceptual data models. The SE service-based information model is published as an open-source component in order to save significant effort in the coordination between service partners and in the implementation of services (on platforms). At the same time, this ensures the interchangeability and interoperability of services.

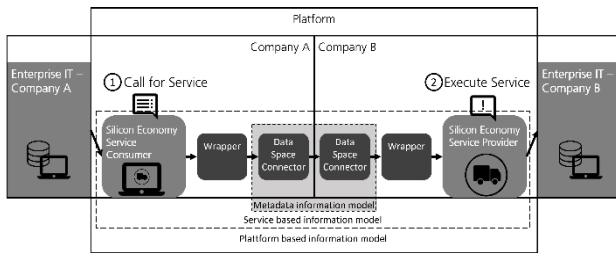

Figure 3.: Architecture and information models for bilateral service execution with connector and wrapper for data exchange

## 5 APPROACH TO GENERATE A SERVICE-BASED INFORMATION MODEL

Within this chapter the generic approach to generate a service-based information model for services in platform-based ecosystems is presented. Basically, the approach is based on three steps (see Figure 4). After identifying a suitable use case in a supply chain or a value network, the process chains must be formally described and modeled (see Section 5.1). In the next step, the data requirements, the events and messages as well as the sources and sinks of the required data are determined with the help of a data flow matrix (see Section 5.2). In the last step, the individual process steps are consolidated into suitable logistic services and the information model is specified (see Section 5.3). A modified form of so-called design sprints proved to be a very efficient format for the creation of information models. Section 5.1 will therefore briefly discuss this.

### First: Process

- Define goals and requirements
- Model or document business process flow
- Break down process into process steps with visibility requirement or data exchange



### Second: Data Flow & Service Definition

- Model for each process step data and event types
- Define event data needs from process steps
- Map information flow (sources and sinks of data)
- Model and document event data down to field level, consider existing standards
- Consolidate process steps to SE services



### Third: Information Model

- Structure all data of one service into a service based information model (logistic function and technical)

Figure 4.: 3-step approach to service-based Information models for logistics services in horizontal supply chains

## 5.1 PROCESS MODELING

When a suitable use case in a supply chain or a value network is identified, the process chains must be formally described and modeled. This can be effectively done by bringing domain experts and developers together in workshops. Additionally, a suitable method is needed to facilitate the modeling and to document the results. There are various approaches and standards for modeling process chains. A few selected are:

EPC is a graphical modeling language for business process workflows. Basic symbols are events, functions, connectors and logical operators. Due to its simplicity EPC is widely used and accepted [KNS92].

Domain storytelling is an interview and modeling method that aims to describe processes in simple stories. During the interviews, experts and developers talk in the domain specific language and write down stories by simple graphical symbols [Hof21].

EventStorming is another workshop format for exploring a business domain. It starts by collecting and ordering domain events. In further steps, commands, actors and aggregates are added [Bra13].

Activity diagrams are behavioral diagrams and are part of the Unified Modeling Language (UML). They allow to model processes and data flows with respect to alternative flows, loops, or concurrency [Bal05].

In the following, the procedure of process modeling using the BPMN (Business Process Model and Notation) method will be explained in more detail, since it is particularly suitable for the representation of processes with many actors and the resulting interfaces [c.f. e.g., Gro09].

BPMN is a graphical specification language in business informatics and process management. It provides symbols with which technical, methodological, and IT specialists can model and document business processes and workflows [cf. e.g., Gro09]. BPMN is an international standard defined by the Object Management Group (OMG), an international standardization body. BPMN aims to structure the sub-processes involved in a service. For this purpose, it divides the business units involved into so-called pools. A pool collects all process activities that are executed by the same business participant. Within the pool, the activities can be further divided into different swim lanes. A swim lane represents the activities of an actor involved in the process. Within the swim lanes, events, activities, and control flow elements are represented and connected. Interactions between different process can also be added by messages (see Figure 5).

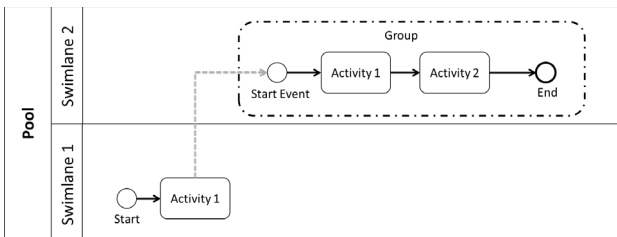

Figure 5.: Schematic overview of BPMN elements (Pool = overall processes, Swimlane = Stakeholder / Actor)

Due to the simplicity of the notation elements BPMN is easy to understand but also allows to model very complex procedures. The included message flow makes the method even more suitable as a pre-work for the service

definition, since it reveals the effort to develop open interfaces depending on possible service boundaries. How the message flow elements are further used to form a data flow matrix is described in the next section.

## 5.2 DATA FLOW MATRIX

Within the next step, the process elements of the BPMN-modeled end-to-end supply chain is transferred into a Data Flow Matrix (see Table 2). Every line in the table of Table 2 represents the structural element (data element, data type, event type, action, data source, or data sink) of the individual process step according to the structure of EPCIS<sup>9</sup>. Each column represents a process step with all relevant information according to the structure. In this way, a matrix is created in which all information and the dependency or interaction between the process participants can be visualized.

Process Step	Process Step 1	Process Step 2	...	Process Step n
<b>Data Element</b> [M 1-n; T 1-n; V 1-n]	V1	T1		Vn
<b>Data Type</b> [Master Data; Transaction Data; Event Data]	Event Data			Event Data
<b>Description</b>	e.g. container empty	e.g. trigger order		e.g. available for consumption
<b>Event Type</b> [e.g. transaction event; kanban order; object event; ...]	transaction event	kanban order		object event
<b>Action</b> [Delete; Add; Observe;...]	Delete			Observe
<b>Source</b> [all Participants of Supply Chain]	Participant 4	Participant 3		Participant 1
<b>Sink 1</b> [all Participants of Supply Chain]	Participant 2	Participant 2		Participant 4
<b>Sink 2</b> [all Participants of Supply Chain]		Participant 4		
<b>Sink n</b> [all Participants of Supply Chain]				

The next step is to identify bundles of process steps which represent a basic (logistic) service in the supply chain. The following criteria help to identify the right process steps to define a Silicon Economy service. All criteria describe mandatory requirements for a Silicon Economy service, i.e., all criteria must be met.

Mandatory criteria:

- A SE service is a functional (logistic) service consisting of IT and / or physical services,
- and is part of a technical / functional (logistic) process.
- A service can be linked to others (services) and subsequently orchestrated in terms of a process.

<sup>9</sup> <https://www.gs1.org/standards/epcis-and-cbv-implementation-guideline/current-standard#Index>



- A service can be integrated into existing (IT) structures.
- A service must be able to be booked and billed.
- A service must be able to be supplied with data.

Table 3. Definition of a Silicon Economy Service

Process Step	Service 1												
	PS 1	PS 2	PS 3	PS 4	PS 5	PS 6	PS 7	PS 8	PS 9	PS 10	PS 11	PS 12	...
Data Element	V1	T1	T2	T3	T4	V2	V3	V4	T5	V5	V6	V7	
Data Type	ED	TD	TD	TD	TD	ED	ED	ED	TD	ED	ED	ED	
Description													
Event Type	te	ko	po	pr	oe	ae	pe	pr	oe	oe	oe	Oe	
Action	del	add				obs				obs	obs	Obs	
Source	P1	P1	P2	P3	P2	P3	P3	P3	P4	P4	P4	P4	
Sink 1	P2	P2		P2		P2	P2	P2	P2	P2	P2	P2	
Sink 2			P3						P3	P3			
Sink n													P1

If the criteria are applied to the process steps of an overall process chain, several process steps can be combined into one SE service (see service 1 in Table 3).

### 5.3 DERIVATION OF A SERVICE-BASED INFORMATION MODEL

The next step is to transfer the Silicon Economy service from the data flow matrix to a service-based information model. The information model represents the technical description of the information that is relevant for the use of the service. The information model also contains and describes the necessary input data to execute the service as well as the returned information (events, confirmations, etc.). The business logic or the process flow is mapped by the sequential structure and the dependencies represented by the information model.

Figure 6 shows the basic and generic structure of a service-based information model of a service within the Silicon Economy. While calling the service, a consumer generates a message to the service provider triggering the execution of the service. Depending on the complexity or scope of the service, further return values (e.g., confirmation) or events are triggered in the logical sequence of the necessary process steps. Each event results in an associated message. Every message would have a „payload“ containing one or more event-, confirmation-, or return value-associated data fields and types.

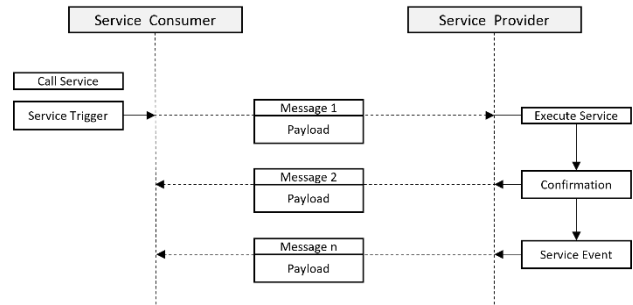

Figure 6.: Generic service-based information model within the Silicon Economy

As mentioned in Section 4.3, (de-facto) standardized service-based information models and the publication as open-source components (information models for the respective logical processes) ensure the interoperability of the services, a fast integration (between partners) and a re-usability of the services in different use cases or applications.

## 6 IMPLEMENTATION / USE CASE

This chapter presents a real-world horizontal supply chain use case. It describes the exemplary implementation of the proposed modeling approach, following the steps in Chapter 5. Starting with a brief introduction of the overall use case and the specific processes, resulting in a defined logistic service and its information model. Paradigmatically a transport service is selected as a common and simple service in federal logistic ecosystems.

### 6.1 USE CASE SUPPLY CHAIN EXECUTION

Today, modern supply chains in terms of value creation networks are often characterized by a high degree of complexity. This can be characterized by both the number of partners involved in the network and other factors such as the complexity of the processes or the variety of products. Horizontal supply chains connect numerous partners and driven by the market are subject to high dynamics. These dynamics can only be countered with flexibility.

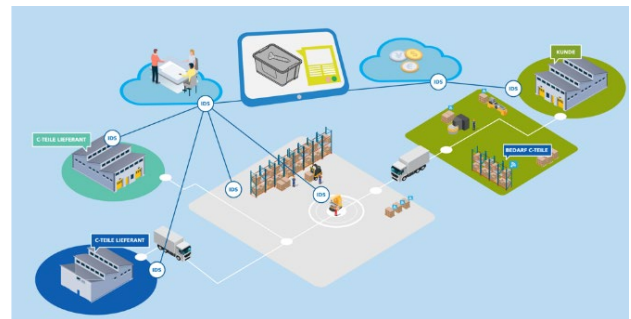

Figure 7.: Supply chain execution big picture

The smooth supply of production with materials and components is an essential function of logistics. The use case considered here (Supply Chain Execution (SCE)) is

the supply of C-parts to producers (see Figure 7). In this case, components that have a relatively low value but are frequently required (e.g., screws, washers, etc.) are provided by service providers directly at or near production or assembly areas via Kanban container systems. In the area of C-parts supply, logistics companies are under pressure to design efficient processes due to the low value of the individual items. At the same time, there is great potential for intelligent services to reduce planning and organizational effort.

In addition to the management of the numerous partners in the network (see Figure 8), particular challenges in C-parts management are as follows:

- Transparency in the supply chain is not available to a sufficient degree.
- Planning reliability is not given or can be significantly increased.
- Processing effort (ordering, transport planning, payment, etc.) is too high (unproductive).
- Search efforts for deliveries not received according to process are high (unproductive).
- IT integration of new partners in the supply chain (e.g., new suppliers of C-parts or logistics service providers) is very time-consuming.

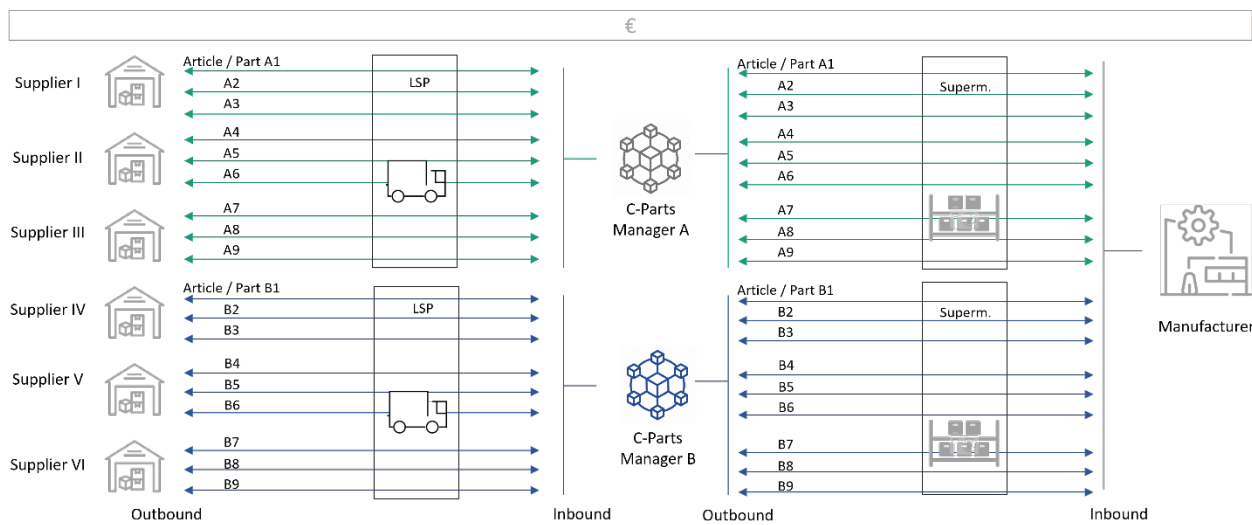

Figure 8.: Horizontal supply chain for c-part supply

The following goals were derived from the challenges of the use case:

- Secure data exchange between the partners (as a basis for the other objectives)
- Improvement or increase in transparency
- Automation of organizational processes in the sense of event-driven services (e.g., transport call-off)
- Significantly reduce IT integration efforts

In the context of generating service-specific information models, the reduction of integration efforts is addressed in particular.

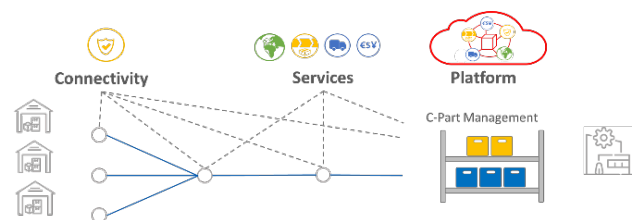

Figure 9.: Step-by-step approach from connectivity to platform integration

As part of the Silicon Economy approach, the necessary components (connector, wrapper, dashboard, etc.) were designed and in some cases already implemented. In the use case, work was carried out step by step, from connecting of partners to orchestration of services on a platform (see Figure 9).

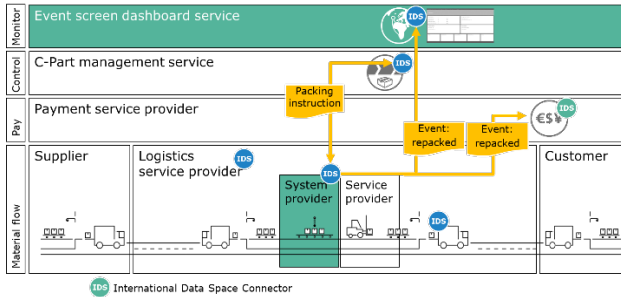

Figure 10.: Functional / organizational level of the SCE project

In the use case (SCE), various process steps or services can be performed in the C-parts management ecosystem. Several levels can be distinguished from the functional / organizational side. There is the lowest level – the material flow, on which all physical movements of the C-parts take place. Further levels are the monetary level (Pay) as well as the control level (Control) and the monitoring level (Monitor).

Figure 9 shows an exemplary repackaging service, within the C-parts supply chain, divided into levels. To repack an article from an unmixed pallet into the corresponding Kanban container, the C-parts manager transfers the corresponding information to the repackaging station, i.e., from the control level to the material flow level. After the physical repackaging, a message is sent to the control level and a corresponding event is generated. This event can be displayed on the dashboard or trigger a payment transaction at the pay level. All notifications and events are securely transmitted via IDS connectors.

As shown in Chapter 5, the processes were described and modeled for the SCE use case and individual process steps were combined into hybrid, physical logistical services (e.g., transport, repackaging, etc.) with a virtual component (event, trigger, notification) or purely digital services (e.g., payment). Information models (see Section 4.3) were derived from the Silicon Economy services, created in this way according to the procedure described. Within the next chapter (see Chapter 6.), one of these information models will be presented.

## 6.2 EXEMPLARY SERVICE BASED INFORMATION MODEL

According to the approach in Chapter 5, the goals and general requirements for the overall supply chain are defined and the process is modeled (see Section 6.1). The documented business process flow for our C-parts supply chain comprises 34 process steps. This includes all activities of the supply chain participants from the empty Kanban container notification to the refilling at the customer. The overall process is consequently broken down into process steps with visibility requirement or a need of data exchange between at least two supply chain participants. In

the C-parts supply chain, suppliers, logistics service providers, payment service providers, system providers, such as the provider of a repackaging station, and a C-parts manager are involved. Based on the overall use case and the process steps mapped in the BPMN a data flow matrix was derived according to Section 5.2. This also implied the description of the source-sink connection of the information to be exchanged to run each process step.

In the data flow matrix, logistical functions could now be identified. They differ from a single process step in the way that a service is provided from one participant to another. The service can be called off and executed and thus can be booked and billed. In the C-parts supply chain, a segmentation of process steps for a particular, but as standardizable as possible, function resulted. Several services related to physical logistic processes were developed. The logistic service provided can be physical, but does not have to. Data services, e.g., for planning, monitoring or payment processing are possible. In this example, we identified goods receipt and goods issue, payment, event data for tracking or the physical transport as appropriate services.

In terms of a service-based information model, these explanations focus on a transport service. Table 4 shows the process steps for the transport service, beginning with a simple pickup request, its confirmation via the physical steps pickup and transportation plus the actual estimated time of arrival (ETA) until the arrival event, which is proofed by an electronic proof of delivery (ePOD). The need for event data from the service's perspective is defined.

Table 4. Process steps and data events of the transport service

Step	Content /Data objects	Data event
1	Pickup Request startAddress, endAddress, pickupDateFrom, pickupDateTo,	T13 pickup request
2	Pick-up confirmation bookingId, pickupDateFrom, pickupDateTo	T14 pickup response
3.1	Pick-up referenceId, timestamp, status, eta	V14 object event
3.2	Ship pallet and Provide ETA referenceId, timestamp, status, eta	V15 object event
3.3	Arrival +ePOD referenceId, timestamp, status	V16 object event

For each process step, the respective transaction or event messages could now be modeled and documented down to field level (see Table 5), considering existing standards.

Table 5. Data fields of a pick-up message

Field Name	Description	Type and Values
eta	Timestamp ETA current status	String acc. ISO 8601 Format
referenceId	Shipment ID which is referred to	String
status	current event	String PICKUP
timestamp	Timestamp of pick-up	ISO 8601

The last step in this approach from a large C-parts supply chain through services to a service-based information model is to structure all data of one service into such an information model. It aggregates the data of a service and can also represent the business logic, as shown in the example in Figure 10.

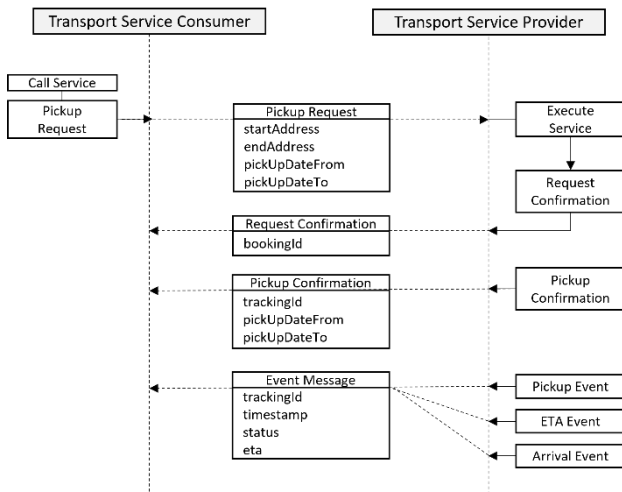

Figure 10: Service based information model for a silicon economy transport service

The resulting information model is the guideline on how to model the information in the implementation of the respective service.

## 7 SUMMARY / OUTLOOK

In the context of this paper, a basic procedure for the creation of information models was presented, according to motivation and state of the art. A special potential was assumed in the reduction of IT integration efforts for all participants in supply chains. This was demonstrated by the exemplary use case from the C-part supply. By the exemplary explanation of a specific information model for the transport of general cargo, the basic structure (at least initially) was presented in addition to the basic procedure for the creation. Using an open-source approach, in which the individual information models for the respective logistic

services (Silicon Economy Services) are published and, if necessary, further developed, standards are created with which the individual partners in a supply chain can program or configure their interfaces. In this way, the bilateral IT integration effort can be significantly reduced.

**Acknowledgement:** This research project was funded by the German Federal Ministry of Transport and Digital Infrastructure (BMVI) within the “Silicon Economy Logistics Ecosystem” project.

## LITERATURE

- [AWS21] Amazon Web Service. (2020): AWS Step Functions. Accessed September 2021. Available: <https://aws.amazon.com/de/step-functions/?step-functions.sort-by=item.additional-Fields.postDateTime&step-functions.sort-order=desc>
- [Bal05] Balzert, H. (2005): Lehrbuch der Objektmodellierung: Analyse und Entwurf mit der UML 2. Heidelberg: Spektrum. ISBN: 978-3-8274-1162-4
- [Böh15] Böhmer, M.; Schmidt, M.; Weißenberg, N. (2015): Seamless Interoperability in Logistics: Narrowing the Business-IT Gap by Logistics Business Objects. In: ten Hompel M., Rehof J., Wolf O. (eds) Cloud Computing for Logistics. Lecture Notes in Logistics. Springer, Cham. [https://doi.org/10.1007/978-3-319-13404-8\\_6](https://doi.org/10.1007/978-3-319-13404-8_6)
- [Bra13] Brandolini, A. (2013): Introducing event storming. Accessed January 2022. Available: <http://ziobrando.blogspot.com/2013/11/introducing-event-storming.html>
- [Cam04] Camarinha-Matos, L. (2004): Virtual Enterprises and Collaborative Networks. In: IFIP 18th World Computer Congress. Toulouse, France: Kluwer Academic Publishers (International Federation for Information Processing (Series)).

- [Del18] Delfmann, W.; ten Hompel, M.; Kersten, W.; Schmidt, T.; Stölzle, W. (2018): Logistics as a science: Central research questions in the era of the fourth industrial revolution, Logistics Research, ISSN 1865-0368, Bundesvereinigung Logistik (BVL), Bremen, 11(9), pp. 1-13.
- [Doc21] Docker (2020): What is a Container? Docker. Accessed January 2022. Available: <https://www.docker.com/resources/what-container>.
- [GS21] GS1 Germany. EPCIS. Accessed January 2022. Available: <https://www.gs1.org/standards/epcis>
- [FhG20] Fraunhofer Gesellschaft. (2020): International Data Spaces. Accessed January 2022. Available: <https://www.fraunhofer.de/de/forschung/fraunhofer-initiativen/international-data-spaces.html>
- [Gei20] Geissbauer, R.; Schrauf, S.; Schneider, J.; Hermans, M. (2020): Connected and autonomous supply chain ecosystems 2025. PWC Study 2020.
- [Gro09] Großkopf, A.; Decker, G.; Weske, M. (2009): The Process: Business Process Modeling using BPMN. Meghan-Kiffer Press.
- [Hof17] Hofmann, E.; Osterwalder, F. (2017): Third-Party Logistics Providers in the Digital Age: Towards a New Competitive Arena? Logistics, 1(2), p. 9.
- [Hof21] Hofer, S.; Schwentner, H. (2021): Domain Storytelling: A Collaborative, Visual, and Agile Way to Build Domain-Driven Software.
- [Hom19] ten Hompel M.; Henke M. (2019): Logistik 4.0 in der Silicon Economy. In: ten Hompel M., Vogel-Heuser B., Bauernhansl T. (eds) Handbuch Industrie 4.0. Springer Reference Technik. Springer Vieweg, Berlin, Heidelberg.
- [Hom21] ten Hompel, M.; Schmidt, M. (2012): Silicon Economy – Logistics as the natural data ecosystem. In: Otto, Boris; ten Hompel, Michael; Wrobel, Stefan (eds.): Designing Data Spaces – The Ecosystem Approach to Competitive Advantage. Springer.
- [INN20a] INNOQ (2020): SCS: Self-Contained Systems. Assembling Software From Independent Systems. Hg. v. innoQ Deutschland GmbH. Accessed January 2022. Available: <https://scs-architecture.org/>
- [INN20b] INNOQ (2020) ISA: Independent Systems Architecture. Principles For Microservices. Hg. v. innoQ Deutschland GmbH. Accessed January 2022. Available: <https://isa-principles.org/>
- [Kam17] Kamp, B.; Parry, G., (2017): Servitization and advanced business services as levers for competitiveness. Industrial Marketing Management, 60.
- [Kel92] Keller, G.; Nüttgens, M.; Scheer, A. (1992): Semantische Prozessmodellierung auf der Grundlage "ereignisgesteuerter Prozessketten (EPK)".
- [Kow17] Kowalkowski, C.; Gebauer, H.; Kamp, B.; Parry, G. (2017): Servitization and deservitization: Overview, concepts, and definitions. Industrial Marketing Management, 60, pp. 4-10.
- [Kub20] Kubernetes (2020): What is Kubernetes? Accessed January 2022. Available: <https://kubernetes.io/docs/concepts/overview/what-is-kubernetes/>
- [Kuh02] Kuhn A.; Hellingrath B. (2002): Supply chain management: Optimierte Zusammenarbeit in der Wertschöpfungskette. Springer, Berlin.
- [Lev21] Leveling, J.; Schier, A.; Sparer, D.; Weissenberg, N. (2021): Silicon Economy – IT-Architektur für die Silicon Economy. In: Otto, Boris; ten Hompel, Michael; Wrobel, Stefan (eds.): Designing Data Spaces – The Ecosystem Approach to Competitive Advantage. Springer.
- [Mel14] Melo; F.; Stine, M. (2014): Developing Microservices for PaaS with Spring and Cloud Foundry. Accessed January 2022. Available: <https://www.infoq.com/presentations/microservices-pass-spring-cloud-foundry/>
- [Moo06] Moore, J. F. (2006): Business ecosystems and the view from the firm. Antitrust Bulletin, 51(1), pp. 31-75.

- [Moo99] Moody, D.; Walsh, P. (1999): Measuring The Value Of Information: An Asset Valuation Approach. In: European Conference on Information Systems 1999, pp. 496–512.
- [Ott16] Otto, B.; Auer, S.; Cirullies, J.; Jürjens, J.; Menz, N.; Schon, J.; Wenzel, S. (2016): Industrial Data Space: Digitale Souveränität über Daten. München, Berlin: Fraunhofer-Gesellschaft; Industrial Data Space e.V.
- [Ott19] Otto et al (2019): Reference Architecture Model, International Data Spaces Association, Release 3.
- [Par13] Parlings, M.; Cirullies, J.; Klingebiel, K. (2013): A literature-based state of the art review on identification and classification of supply chain design tasks. In: Proceedings of the 17th Cambridge international manufacturing symposium.
- [Pau20] Paukstadt, U.; Strobel, G.; Eicker, S.; Becker, J. (2020): Smart Services und ihr Einfluss auf die Wertschöpfung und Geschäftsmodelle von Unternehmen. In: Kollmann T. (eds) Handbuch Digitale Wirtschaft. Springer Gabler, Wiesbaden. [https://doi.org/10.1007/978-3-658-17291-6\\_83](https://doi.org/10.1007/978-3-658-17291-6_83)
- [PI19] Plattform Industrie 4.0 (2019): Digitale Ökosysteme Global Gestalten. Unpublished manuscript, last modified May 25, 2021. Available: [https://www.plattform-i40.de/PI40/Redaktion/DE/Downloads/Publikation/Leitbild-2030-f%C3%BCr-Industrie-4.0.pdf?\\_\\_blob=publication-File&v=11](https://www.plattform-i40.de/PI40/Redaktion/DE/Downloads/Publikation/Leitbild-2030-f%C3%BCr-Industrie-4.0.pdf?__blob=publication-File&v=11)
- 
- M.Sc. Emanuel Skubowius, Dipl.-Inf. Benjamin Korth, M.Sc. Jens Leveling, M.Sc. Timo Erler, Dipl.-Logist. Christian Prasse\*, Dr.-Ing. Michael Schmidt**  
Fraunhofer Institute for Material Flow and Logistics IML, Joseph-von-Fraunhofer-Straße 2-4, 44227 Dortmund, Germany.  
Phone: +49 231 9743-0  
<https://www.impl.fraunhofer.de/>  
**\*Corresponding author:**  
[christian.prasse@impl.fraunhofer.de](mailto:christian.prasse@impl.fraunhofer.de)
- M.Sc. Johannes Pieperbeck**  
Fraunhofer Institute for Software and Systems Engineering ISST, Emil-Figge-Straße 91, 44227 Dortmund, Germany  
<https://www.isst.fraunhofer.de/>
- M.Sc. Gong Wang, M.Sc. Filip-Martin Brinkmann**  
SICK AG  
Erwin-Sick-Str. 1, 79183 Waldkirch, Germany  
<http://www.sick.de>
- B.Sc. Vincent Zupancic**  
Schenker AG  
Kruppstr. 4, 45128 Essen, Germany  
<https://www.dbschenker.com>